

MANUAL OFFSETTABLE BIFOLD BOOM EXTENSION

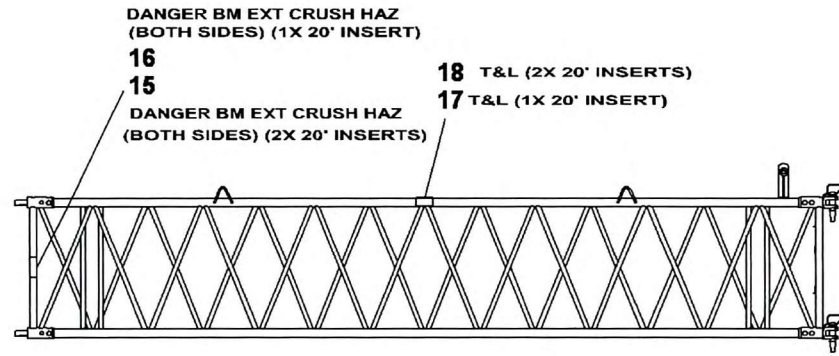

20' BOOM EXTENSION INSERTS

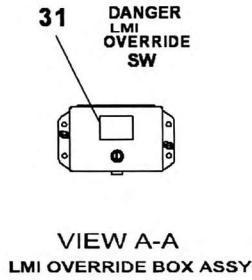
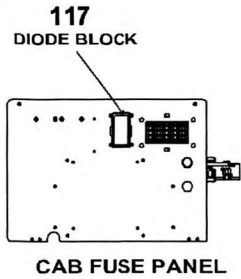
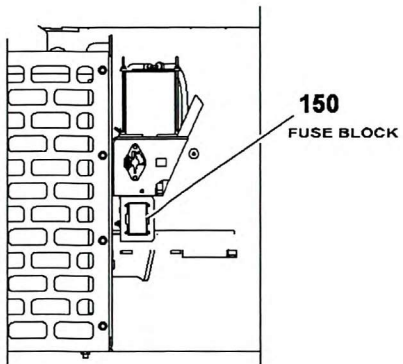

BATTERY COMPARTMENT

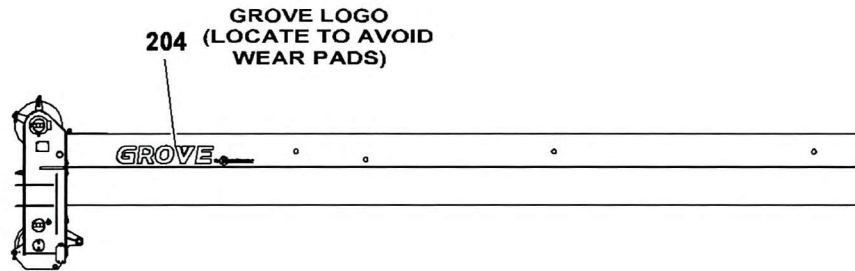

### PARTIAL TOP VIEW OF S/S TURNTABLE

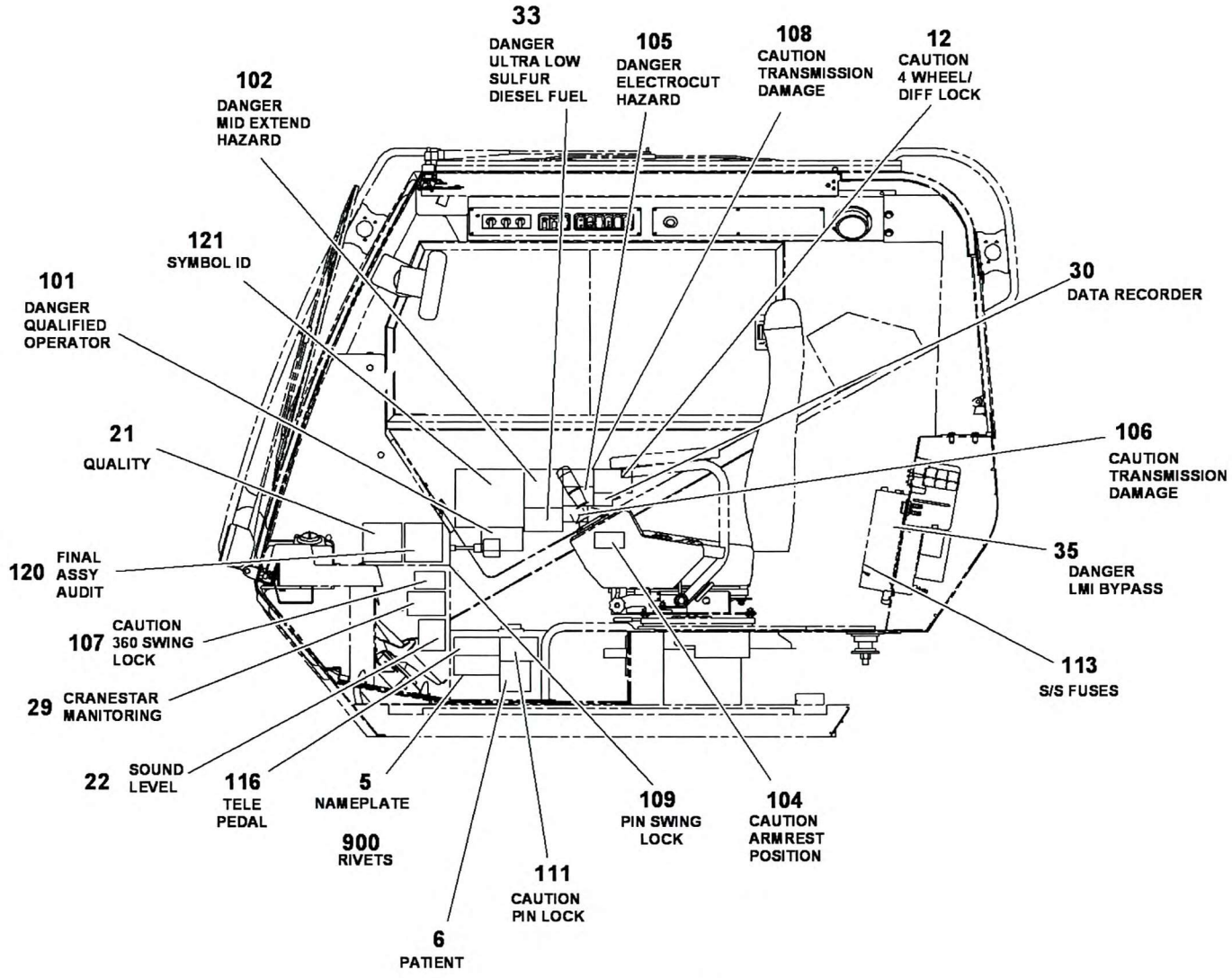

CAB INSIDE VIEW

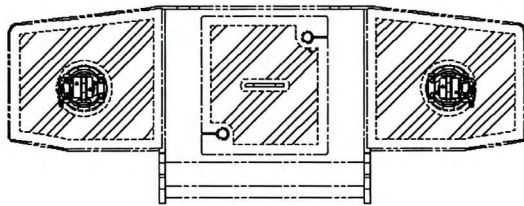

COUNTERWEIGHT TOP VIEW W/IPO

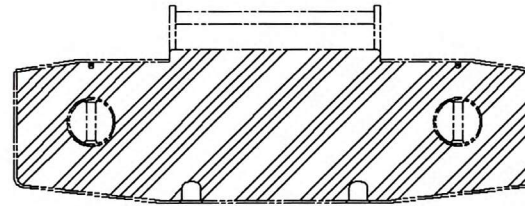

COUNTERWEIGHT BOTTOM VIEW

HATCHING DENOTES NON-SKID PAINT AREA.

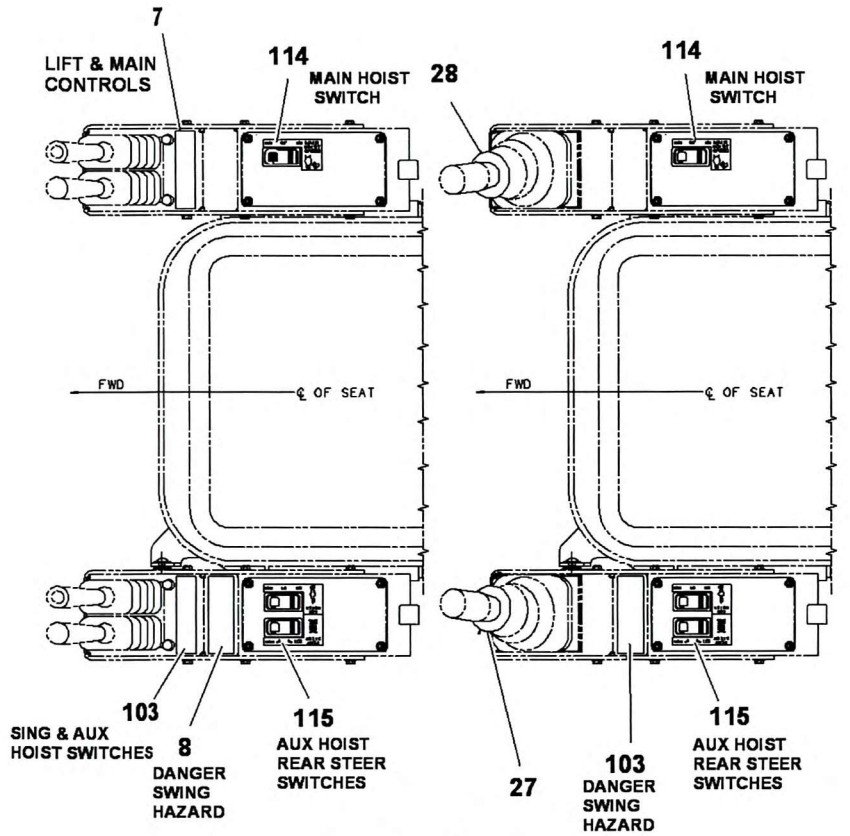

SINGLE AXIS CONTROLLERS

DUAL AXIS CONTROLLERS (CE)

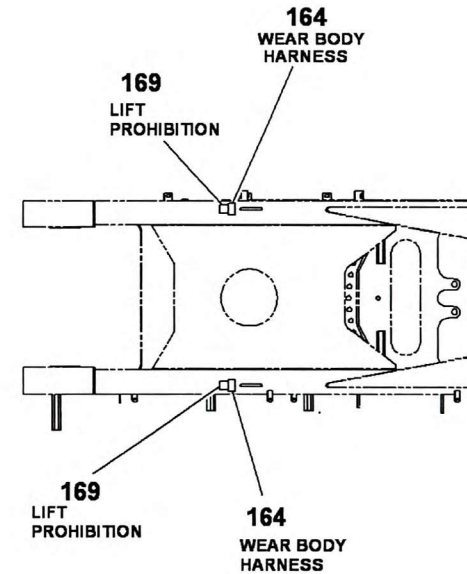

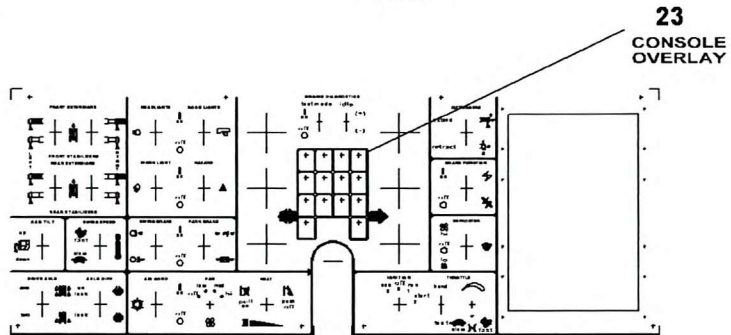
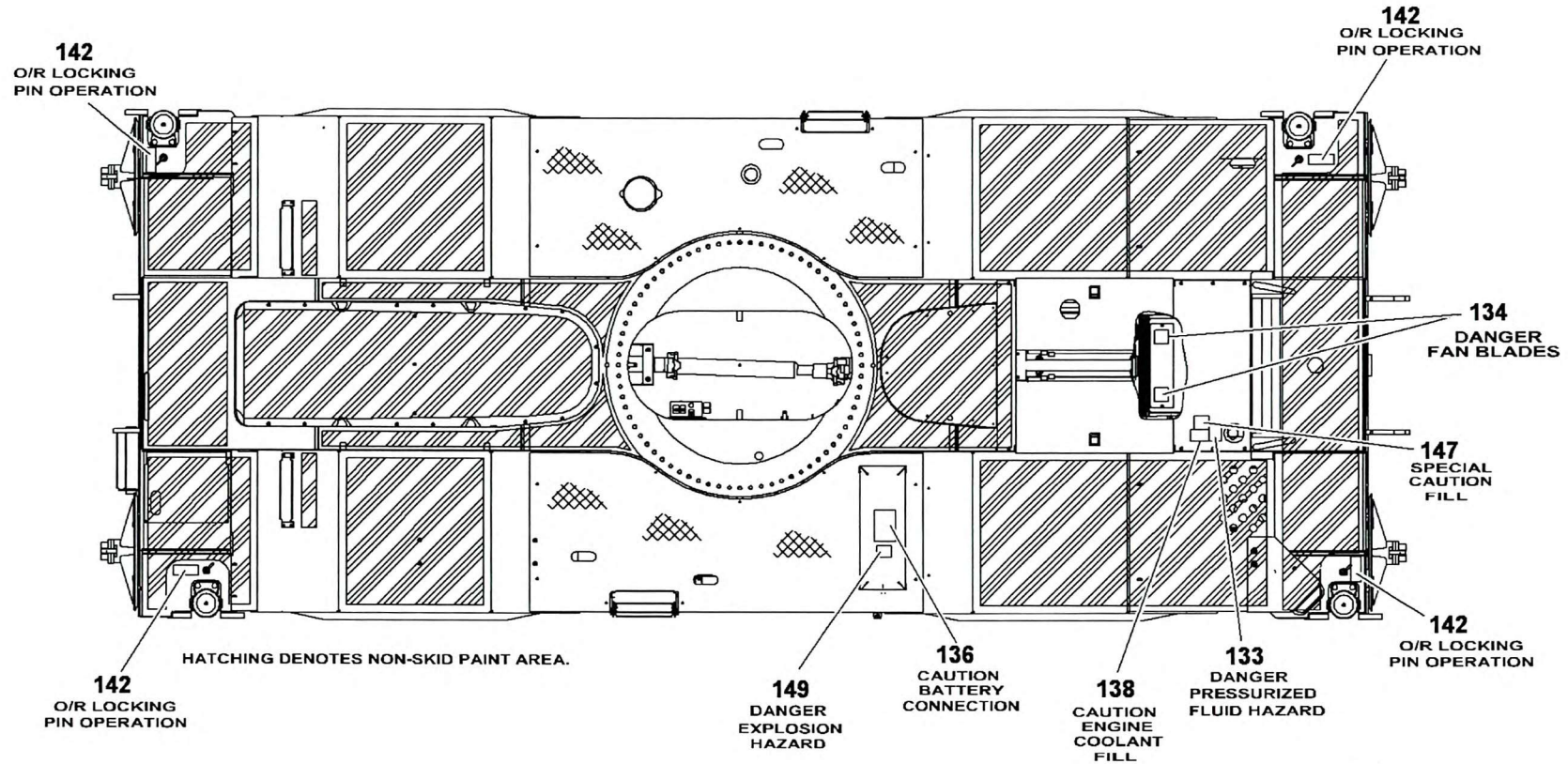

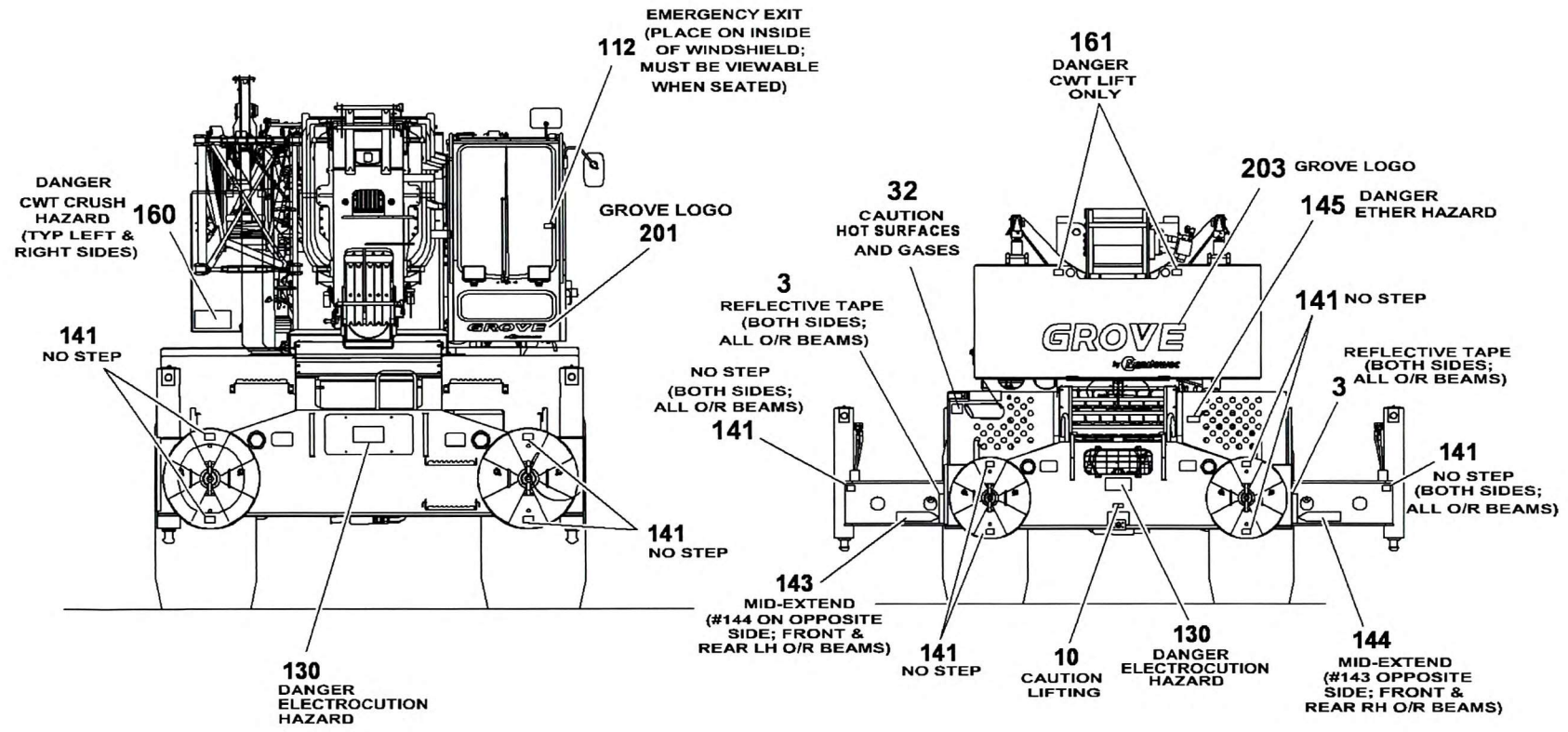

(SHEET 2 OF 6)

Page 807

80031109

